

| | | | | | | | | | | |
|---------------------|--|--|--|--|--|------------------|--|--|--|--|
| Centre Number | | | | | | Candidate Number | | | | |
| Surname | | | | | | | | | | |
| Other Names | | | | | | | | | | |
| Candidate Signature | | | | | | | | | | |

| | |
|---------------------|------|
| For Examiner's Use | |
| Examiner's Initials | |
| Question | Mark |
| 1 | |
| 2 | |
| 3 | |
| 4 | |
| 5 | |
| 6 | |
| 7 | |
| 8 | |
| TOTAL | |



General Certificate of Secondary Education
Foundation Tier
June 2013

Physics

Unit Physics P3

PH3FP

F

Thursday 23 May 2013 9.00 am to 10.00 am

For this paper you must have:

- a ruler
- a calculator
- the Physics Equations Sheet (enclosed).

Time allowed

- 1 hour

Instructions

- Use black ink or black ball-point pen.
- Fill in the boxes at the top of this page.
- Answer **all** questions.
- You must answer the questions in the spaces provided. Do not write outside the box around each page or on blank pages.
- Do all rough work in this book. Cross through any work you do not want to be marked.

Information

- The marks for questions are shown in brackets.
- The maximum mark for this paper is 60.
- You are expected to use a calculator where appropriate.
- You are reminded of the need for good English and clear presentation in your answers.
- Question 8(a) should be answered in continuous prose. In this question you will be marked on your ability to:
 - use good English
 - organise information clearly
 - use specialist vocabulary where appropriate.

Advice

- In all calculations, show clearly how you work out your answer.



J U N 1 3 P H 3 F P O 1

G/K95448 6/6/6/6/6

PH3FP

Answer **all** questions in the spaces provided.

1 (a) Visible light can be sent along optical fibres.

Which diagram correctly shows the path of light along an optical fibre?

Tick (✓) **one** box.

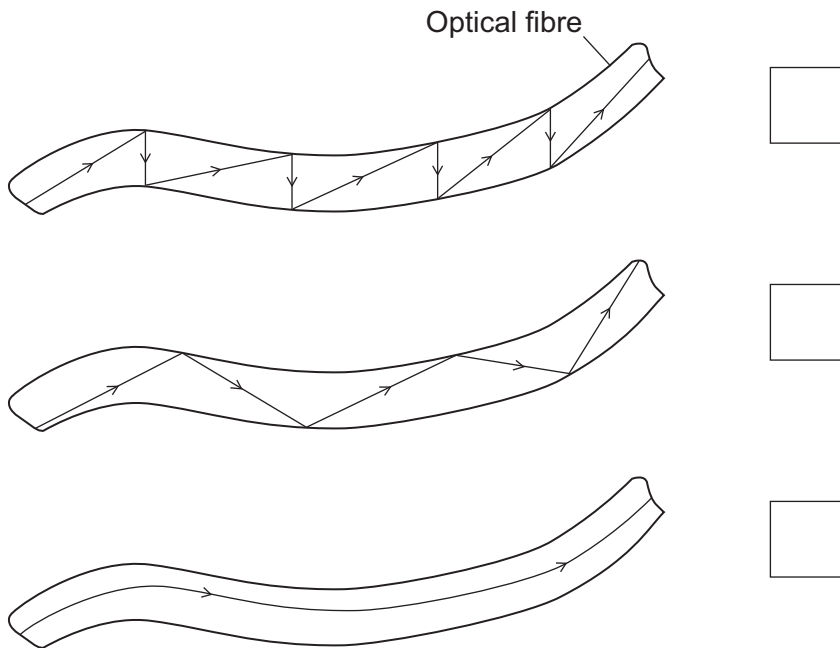

(1 mark)

1 (b) Complete the sentence to describe what happens to light as it travels through an optical fibre.

At the walls of the optical fibre, light undergoes total internal
(1 mark)



- 1 (c)** Which device passes light through optical fibres to produce images of the inside of the body?

Draw a ring around the correct answer.

endoscope

stethoscope

X-ray machine

(1 mark)

- 1 (d)** Lasers are an energy source.

Which **one** of the following is a use for a laser?

Draw a ring around the correct answer.

CT scanning

digital camera

eye surgery

(1 mark)

| |
|----------|
| |
| 4 |

Turn over for the next question

Turn over ►



2 (a) The diagram shows the structure of a traditional transformer.

Use words from the box to label the diagram.

aluminium brass iron large primary secondary

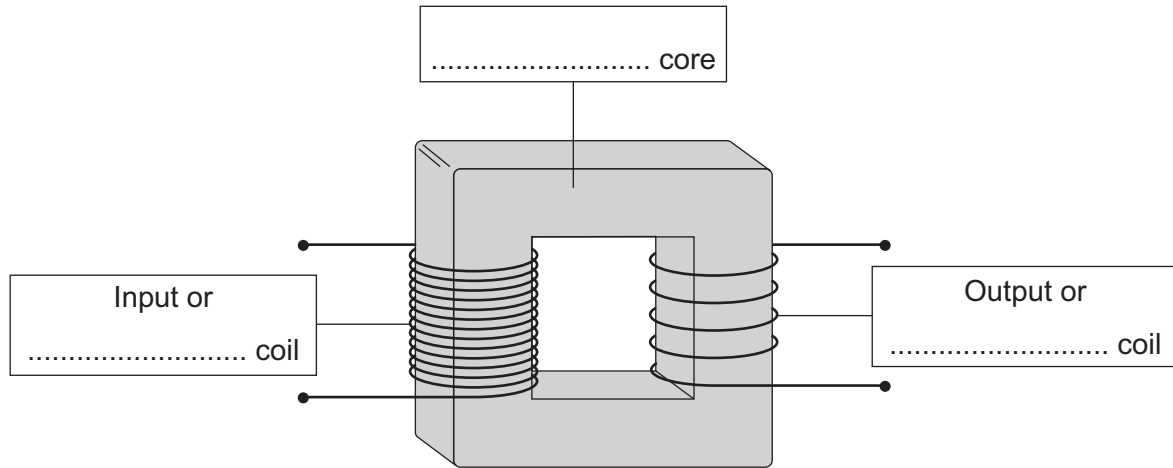

(3 marks)

2 (b) Batteries inside laptop computers are charged using laptop chargers. The laptop charger contains a traditional transformer.

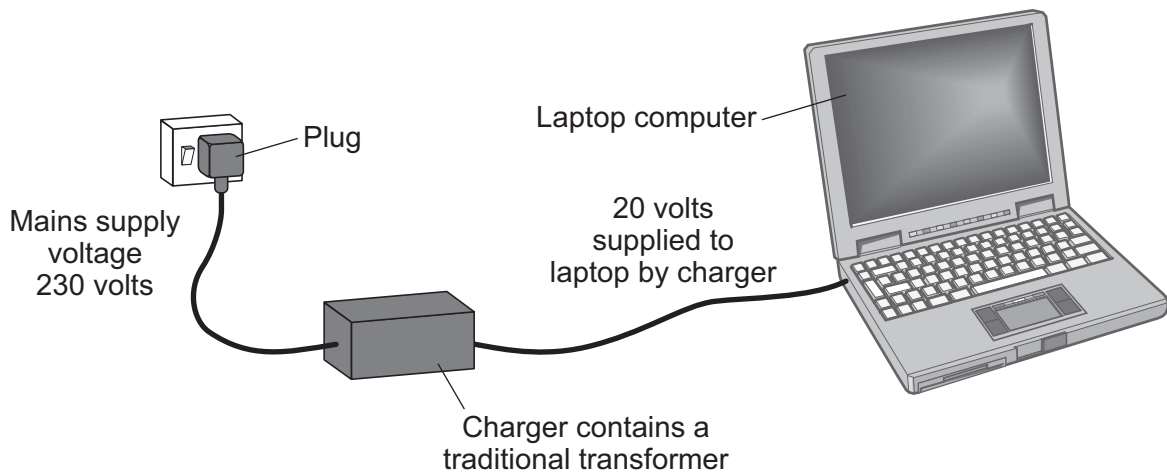

The laptop charger contains a step-down transformer.

What does a step-down transformer do?

.....
.....

(1 mark)

2 (c)

The transformer used in a modern mobile phone charger is a switch mode transformer. This is different to the traditional transformer used in the laptop charger.

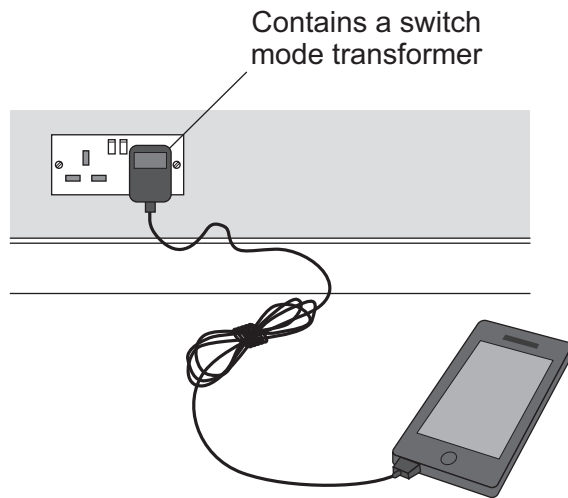

Give **one** advantage of using a switch mode transformer, rather than a traditional transformer.

.....
.....

(1 mark)

2 (d)

Laptop batteries and mobile phone batteries can only be recharged a limited number of times. When a battery cannot be recharged, it is better to recycle the battery than to throw it away.

Draw a ring around the correct answer to complete the sentence.

The batteries are recycled mainly due to

| |
|------------------|
| an environmental |
| a political |
| a social |

consideration.

(1 mark)

| |
|---|
| |
| 6 |

Turn over ►



3 (a) The diagram shows a pendulum.

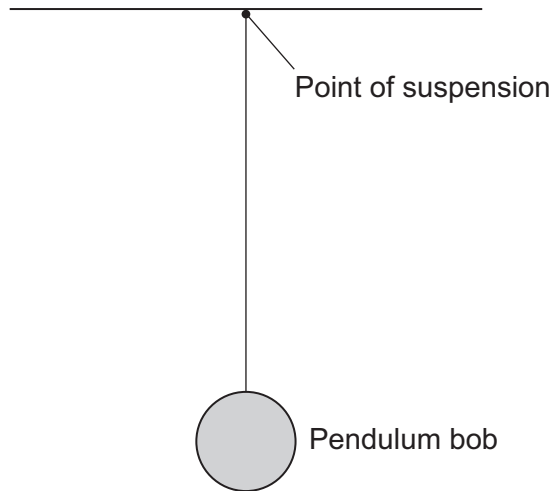

Draw an X on the diagram above, so that the centre of the **X** marks the centre of mass of the pendulum bob.

(1 mark)

3 (b) A large clock keeps time using the swing of a pendulum.

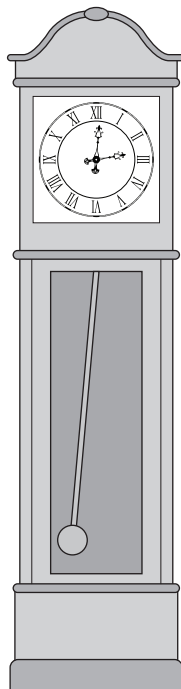

3 (b) (i) The frequency of the swinging pendulum is 0.5 hertz.

Calculate the periodic time of the pendulum.

Use the correct equation from the Physics Equations Sheet.

.....
.....
.....

Periodic time = seconds
(2 marks)

3 (b) (ii) Calculate the number of complete swings the pendulum would make in 60 seconds.

Use your answer from part **(b)(i)** in your calculation.

.....
.....
.....

Number of swings in 60 seconds =
(2 marks)

Question 3 continues on the next page

Turn over ►



3 (c) The diagram shows a clock on a trolley.

The trolley is being used to move the clock.

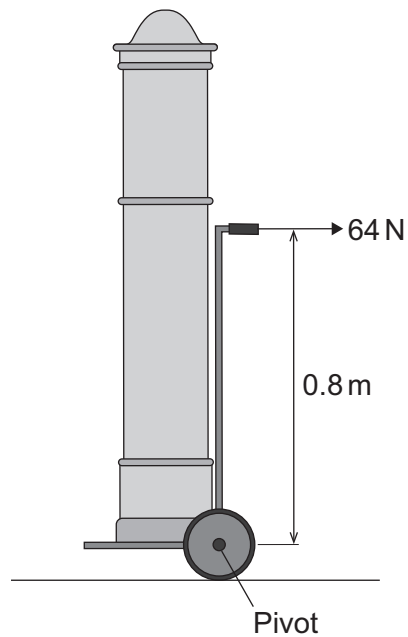

Calculate the moment of the 64 N force about the pivot.

Use the correct equation from the Physics Equations Sheet.

.....

.....

.....

Moment of the force = Nm
(2 marks)



3 (d) The design of the trolley is now changed to make it taller.

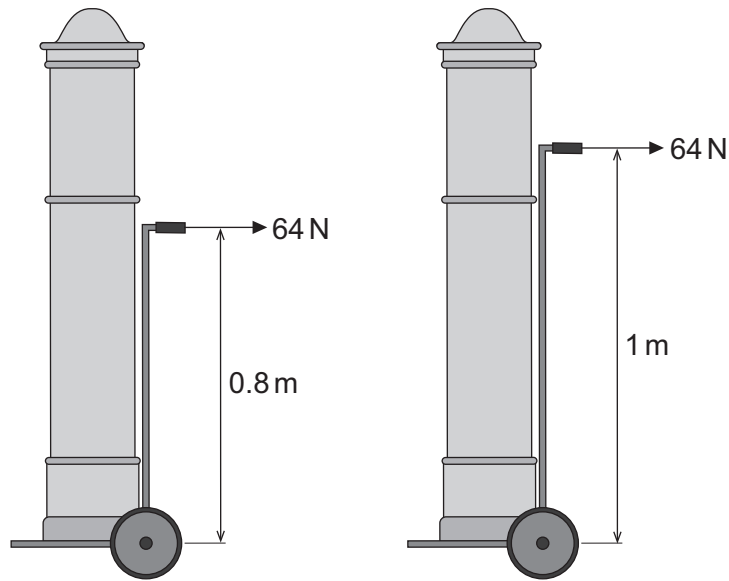

How does making the trolley taller affect the moment produced by the 64 N force about the pivot?

.....

.....

(1 mark)

| |
|---|
| 8 |
|---|

Turn over for the next question

Turn over ►



- 4 An event involved paddling a homemade raft down a fast-flowing river. The rafts were made using empty barrels.



- 4 (a) (i) Which **two** factors would most affect the raft's stability?

Tick (✓) the **two** correct factors.

The cost of the raft

The width of the base of the raft

The position of the centre of mass of the raft

How streamlined the raft is

(2 marks)



4 (a) (ii) Here are three raft designs:

Design A

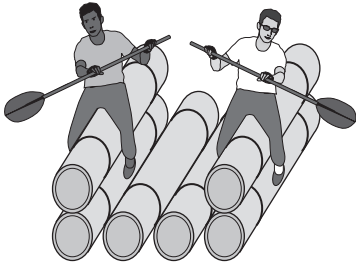

Design B

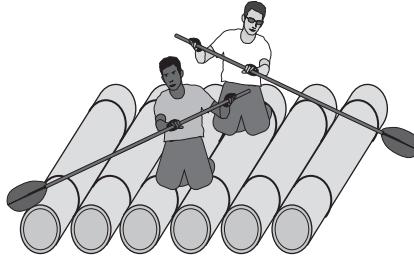

Design C

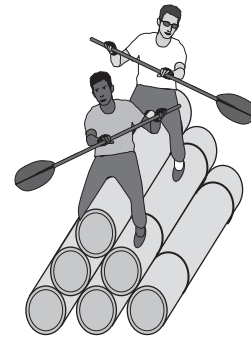

Which design of raft would be most stable?

Tick (✓) **one** box.

Design A

Design B

Design C

(1 mark)

Question 4 continues on the next page

Turn over ►



4 (b) A camera was used to take photographs of the rafts. The camera contains a convex (converging) lens. The ray diagram shows how the lens produces an image.

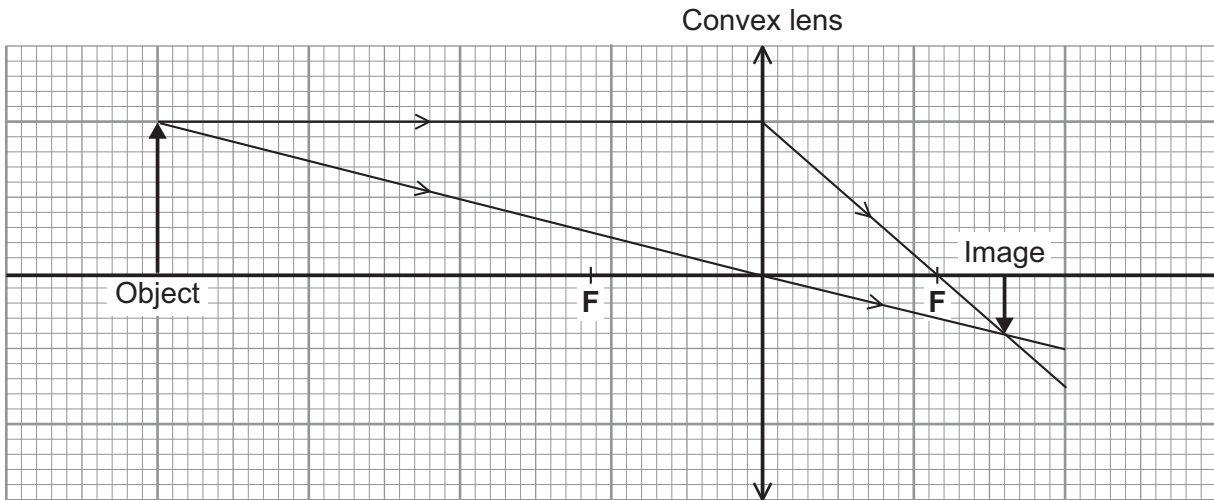

F = Principal focus

4 (b) (i) Which **two** words from the list describe the nature of the image?

Draw a ring around each of the **two** correct answers.

- upright** **magnified** **inverted** **virtual** **real**

(2 marks)

4 (b) (ii) Use information from the ray diagram to calculate the magnification of the image.

Use the correct equation from the Physics Equations Sheet.

.....

.....

.....

Magnification =
(2 marks)



4 (c) A different type of lens is a concave (diverging) lens.

Which diagram shows a concave (diverging) lens?

Tick (✓) **one** box.

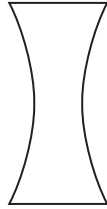

(1 mark)

| |
|---|
| |
| 8 |

Turn over for the next question

Turn over ►



5 The diagram shows a 'G-machine'. The G-machine is used in astronaut training.

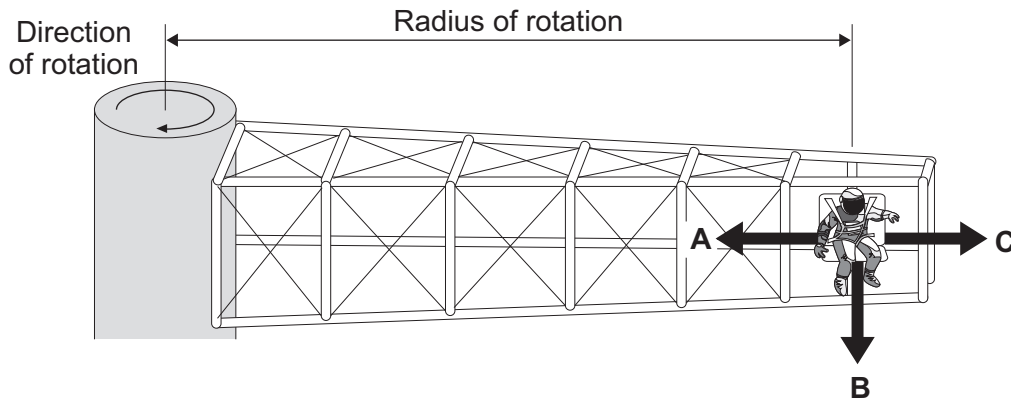

The G-machine moves the astronaut in a horizontal circle.

5 (a) In which direction, **A**, **B** or **C**, does the centripetal force on the astronaut act?

Write your answer in the box.

(1 mark)

5 (b) The centripetal force on the astronaut is measured.

Graph X shows how the centripetal force is affected by the speed of rotation. The radius of rotation is kept the same.

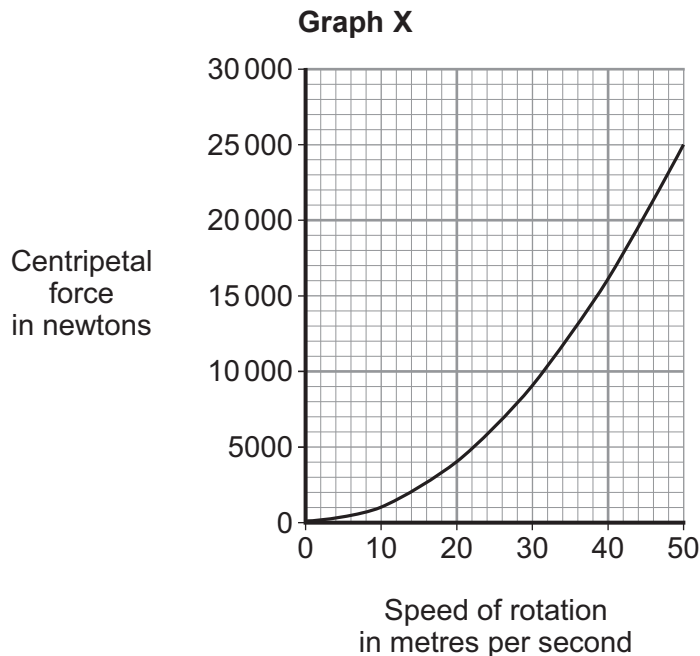

5 (b) (i) Use **Graph X** to determine the centripetal force on the astronaut when rotating at a speed of 30 metres per second.

Centripetal force = newtons
(1 mark)



5 (b) (ii) Complete the following sentence to give the conclusion that can be made from **Graph X**.
Increasing the speed of rotation of a G-machine will
the centripetal force on the astronaut.
(1 mark)

5 (b) (iii) **Graph Y** shows how the centripetal force is affected by the radius of rotation, when the speed of rotation is kept the same.

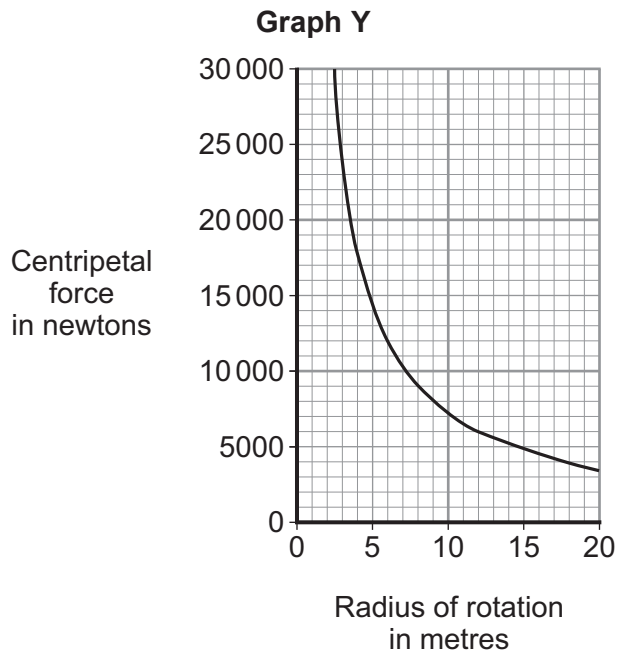

Complete the following sentence to give the conclusion that can be made from **Graph Y**.
The greater the radius of rotation, the the centripetal force on
the astronaut.
(1 mark)

Question 5 continues on the next page

Turn over ►



- 5 (c)** The G-machine is rotated by an electric motor. The diagram shows a simple electric motor.

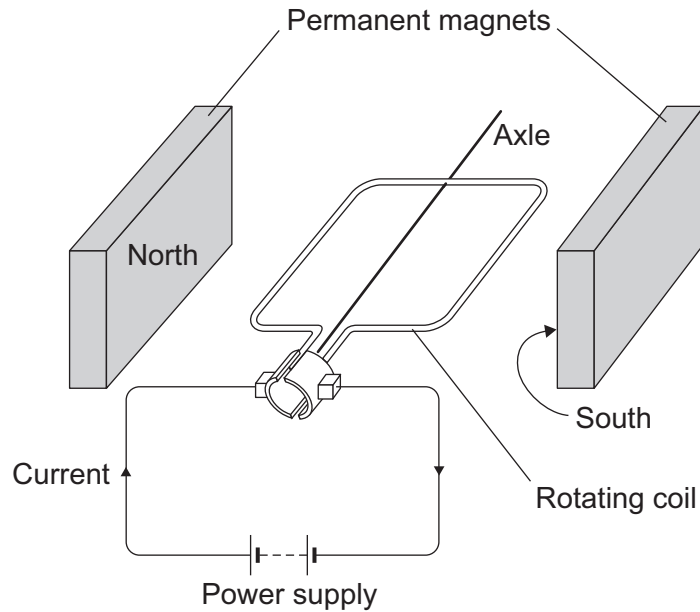

The following statements explain how the motor creates a turning force. The statements are in the wrong order.

- M** – The magnetic field interacts with the magnetic field of the permanent magnets.
- N** – A magnetic field is created around the coil.
- O** – The power supply applies a potential difference across the coil.
- P** – This creates a force that makes the coil spin.
- Q** – A current flows through the coil.

Arrange the statements in the correct order. Two of them have been done for you.



(2 marks)



5 (d) The electric motor produces a turning force.

Give **two** ways of increasing the turning force.

1

.....

2

.....

(2 marks)

5 (e) Draw a ring around the correct answer to complete the sentence.

It costs a lot of money to send astronauts into space.

This is _____ issue.

- an economic
- an environmental
- a social

(1 mark)

| |
|----------|
| |
| 9 |

Turn over for the next question

Turn over ►



6 Mountain bike riders use brakes to slow down.

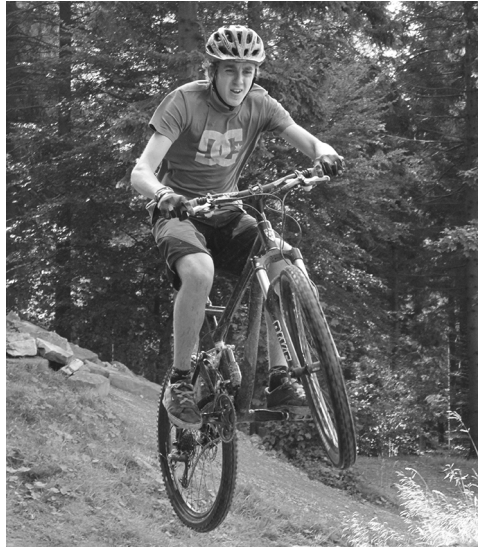

Some mountain bikes use liquid-filled pipes to transmit the force from the rider's hand on the brake lever to the brake pads. These brakes are called hydraulic brakes.

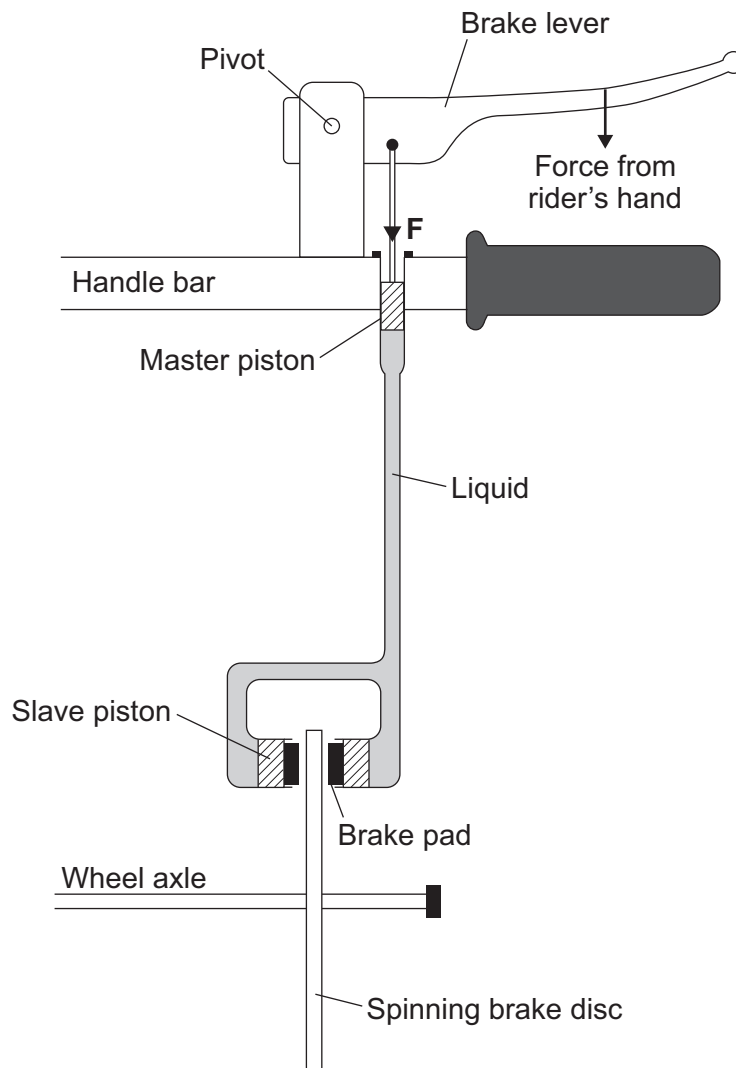

7 (a) The diagram shows parts of the human eye.
Complete the missing labels.

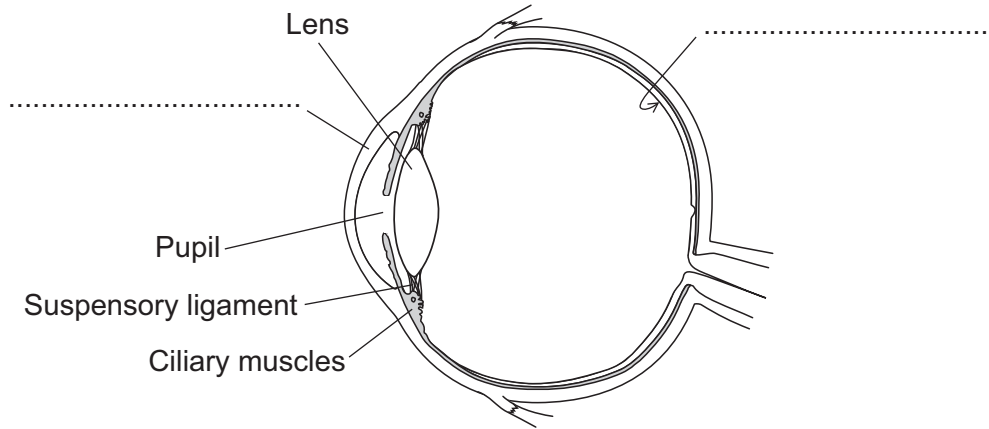

(2 marks)

7 (b) Each part of the human eye has a function.
Complete the table below.

| Part of the human eye | Function of the part |
|-----------------------|-----------------------------------------------------------------------|
| | Changes size to make sure the correct amount of light enters the eye. |
| Ciliary muscles | |
| Lens | |

(3 marks)



7 (c) The human eye can focus on near objects. The closest distance the eye can bring into sharp focus is called the near point.

A student measured the near point of four people of different ages. The table shows her data.

| Age of human in years | Near point in millimetres |
|-----------------------|---------------------------|
| 10 | 200 |
| 25 | 250 |
| 40 | 400 |
| 55 | 700 |

What can you conclude from the data in the table above?

.....

.....

.....

.....

(2 marks)

7 (d) Suggest how the data obtained by the student could be improved.

.....

.....

(1 mark)

7 (e) Spectacles are worn to correct vision. One of the lenses in a pair of spectacles has a focal length of 40 centimetres.

Calculate the power of the lens.

Use the correct equation from the Physics Equations Sheet.

.....

.....

.....

Power of lens = diopres
(2 marks)

| |
|----|
| 10 |
|----|

Turn over ►



8 Ultrasound and X-rays are waves used in hospitals to create images of the inside of the human body. To produce the images below, the waves must enter the human body.

Ultrasound scan of an unborn child



X-ray of a broken bone



8 (a) *In this question you will be assessed on using good English, organising information clearly and using specialist terms where appropriate.*

Describe the features of ultrasound and X-rays, and what happens to each type of wave after it has entered the human body.

.....

.....

.....

.....

.....

.....

.....

.....

.....

.....

.....

.....

.....

.....

.....

.....

.....

.....

.....

.....

.....

.....

.....

.....

(6 marks)



8 (b) It would **not** be safe to use X-rays to produce an image of an unborn child.

Explain why.

.....
.....
.....
.....

(2 marks)

8 (c) Ultrasound can be used for medical treatments as well as for imaging.

Give **one** use of ultrasound for medical treatment.

.....
.....

(1 mark)

| |
|---|
| |
| 9 |

END OF QUESTIONS



There are no questions printed on this page

**DO NOT WRITE ON THIS PAGE
ANSWER IN THE SPACES PROVIDED**

ACKNOWLEDGEMENT OF COPYRIGHT-HOLDERS AND PUBLISHERS

Question 4: Photograph of raft © Tom Foxall
Question 6: Photograph of mountain biker © Tom Foxall
Question 8: Photograph of an unborn child © Thinkstock
Question 8: Photograph of a broken bone © Getty Images

Copyright © 2013 AQA and its licensors. All rights reserved.

