

GCSE Mathematics Specification (8300/2H)

H

Paper 2 Higher tier

Date

Morning

1 hour 30 minutes

Materials

For this paper you must have:

- a calculator
- mathematical instruments.



Instructions

- Use black ink or black ball-point pen. Draw diagrams in pencil.
- Fill in the boxes at the bottom of this page.
- Answer **all** questions.
- You must answer the questions in the spaces provided. Do not write outside the box around each page or on blank pages.
- Do all rough work in this book.
- In all calculations, show clearly how you work out your answer.

Information

- The marks for questions are shown in brackets.
- The maximum mark for this paper is 80.
- You may ask for more answer paper, graph paper and tracing paper. These must be tagged securely to this answer book.

Please write clearly, in block capitals, to allow character computer recognition.

Centre number

Candidate number

Surname

Forename(s)

Candidate signature _____

Answer **all** questions in the spaces provided.

1 Which sequence is a geometric progression?

Circle your answer.

[1 mark]

1 2 3 4

1 2 4 7

1 2 4 8

1 2 3 5

2 Which of these is **not** used to prove that triangles are congruent?

Circle your answer.

[1 mark]

SSS

SAS

AAA

RHS

3 Circle the expression that is equivalent to $2a + 5a \times 4a - a$

[1 mark]

$$a + 20a^2$$

$$21a^2$$

$$28a^2 - a$$

$$2a + 15a^2$$

4 Circle the equation of a line that is parallel to $y = 5x - 2$

[1 mark]

$$y = 2x - 5$$

$$y = 5x + 2$$

$$y = 3x - 2$$

$$y = -\frac{1}{5}x - 2$$

5 In a sale, the original price of a bag was reduced by $\frac{1}{5}$

The sale price of the bag is £29.40

Work out the original price.

[3 marks]

Answer £ _____

Turn over for the next question

6 $\xi = \{1, 2, 3, 4, 5, 6, 7, 8, 9, 10, 11, 12\}$

S = square numbers

E = even numbers

6 (a) Complete the Venn diagram.

[3 marks]

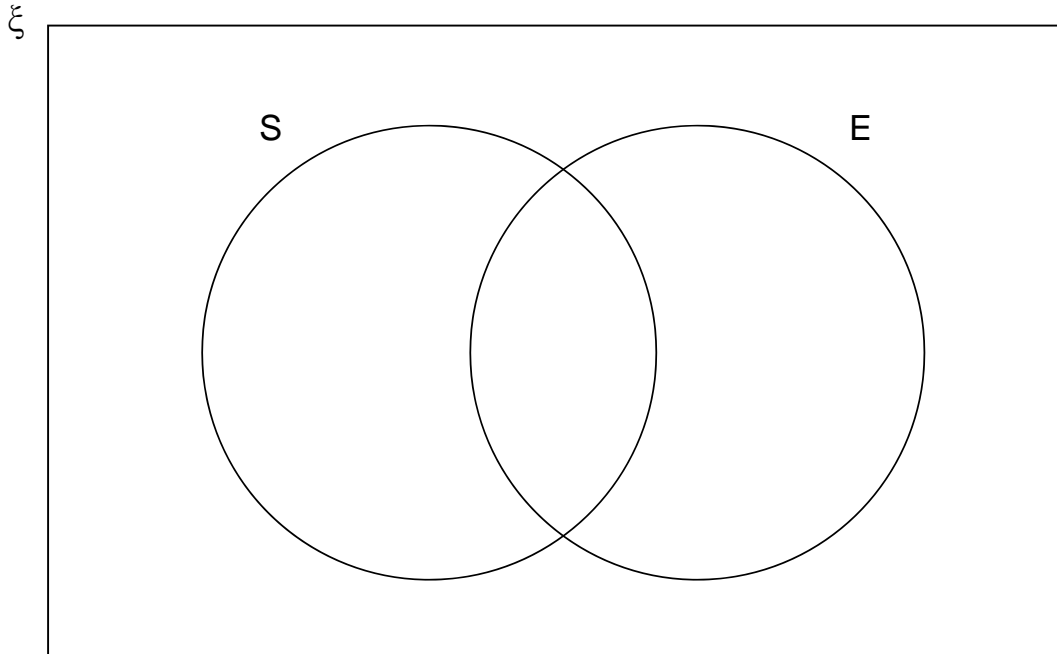

6 (b) One of the numbers is chosen at random.

Write down $P(S \cap E)$

[1 mark]

Answer _____

- 7** A coin is rolled onto a grid of squares.
It lands randomly on the grid.
To win, the coin must land completely within one of the squares.

Meera and John each roll the coin a number of times and record their results.

	Number of wins	Number of losses
Meera	6	44
John	28	72

- 7 (a)** Work out **two** different estimates for the probability of winning.

[2 marks]

Answer _____ and _____

- 7 (b)** Which of your estimates is the better estimate for the probability of winning?
Give a reason for your answer.

[1 mark]

Answer _____

Reason _____

- 8 Here is the graph of $4x - 3y = 12$ for values of x from 0 to 4

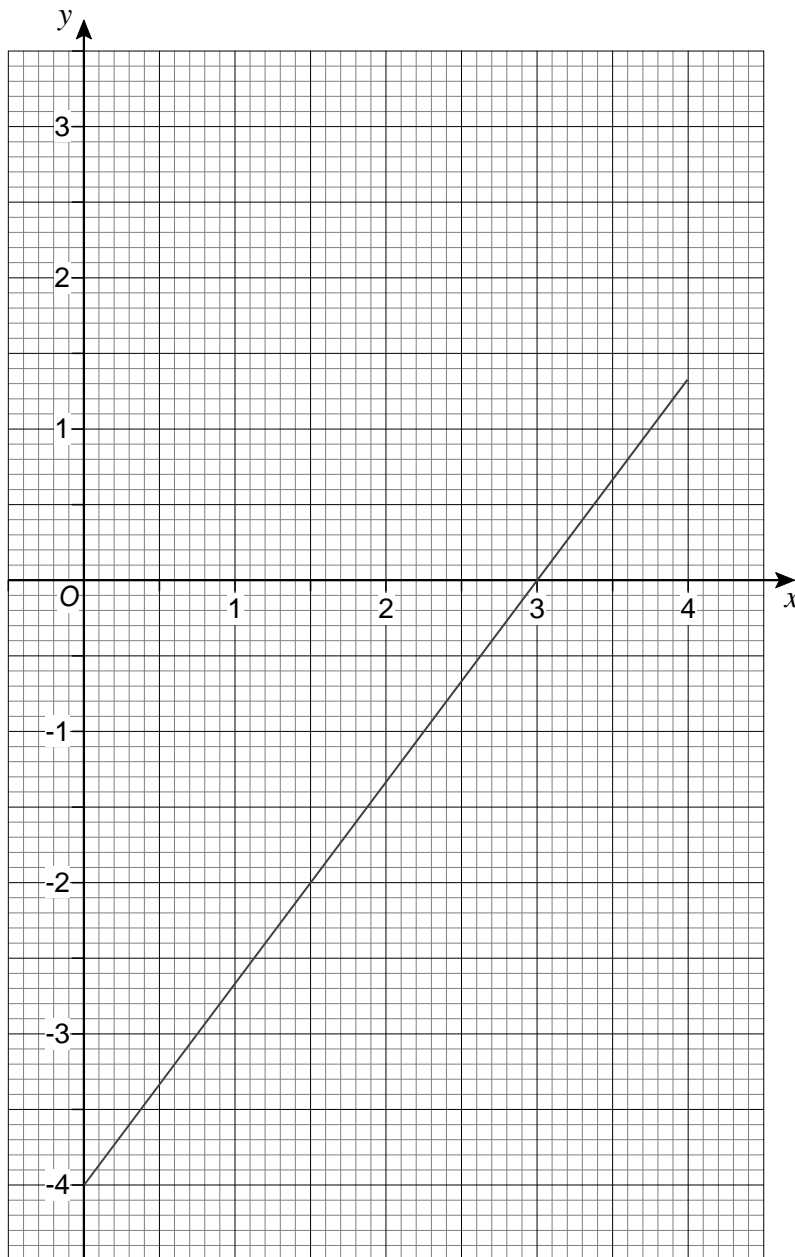

By drawing a second graph on the grid,
work out an approximate solution to the simultaneous equations

$$4x - 3y = 12 \quad \text{and} \quad 3x + 2y = 6$$

[3 marks]

Answer _____

9 Written as the product of its prime factors

$$672 = 2^5 \times 3 \times 7$$

9 (a) Write 252 as the product of its prime factors.

[2 marks]

Answer _____

9 (b) Work out the value of the highest common factor of 672 and 252

[1 mark]

Answer _____

Turn over for the next question

10 At a school

number of boys : number of girls = 9 : 7

There are 116 **more** boys than girls.

Work out the total number of students at the school.

[3 marks]

Answer _____

11 Circle the equation with roots 4 and -8

[1 mark]

$$4x(x - 8) = 0$$

$$(x - 4)(x + 8) = 0$$

$$x^2 - 32 = 0$$

$$(x + 4)(x - 8) = 0$$

12 $R = \frac{x^2}{y}$

$$x = 3.6 \times 10^5$$

$$y = 7.5 \times 10^4$$

Work out the value of R .

Give your answer in standard form to an appropriate degree of accuracy.

[3 marks]

Answer _____

13 Two spheres have radii in the ratio 5 : 3

Circle the ratio of their volumes.

[1 mark]

5 : 3

15 : 9

25 : 9

125 : 27

Turn over for the next question

14 (a) A pattern is made from two **similar** trapeziums.

Not drawn accurately

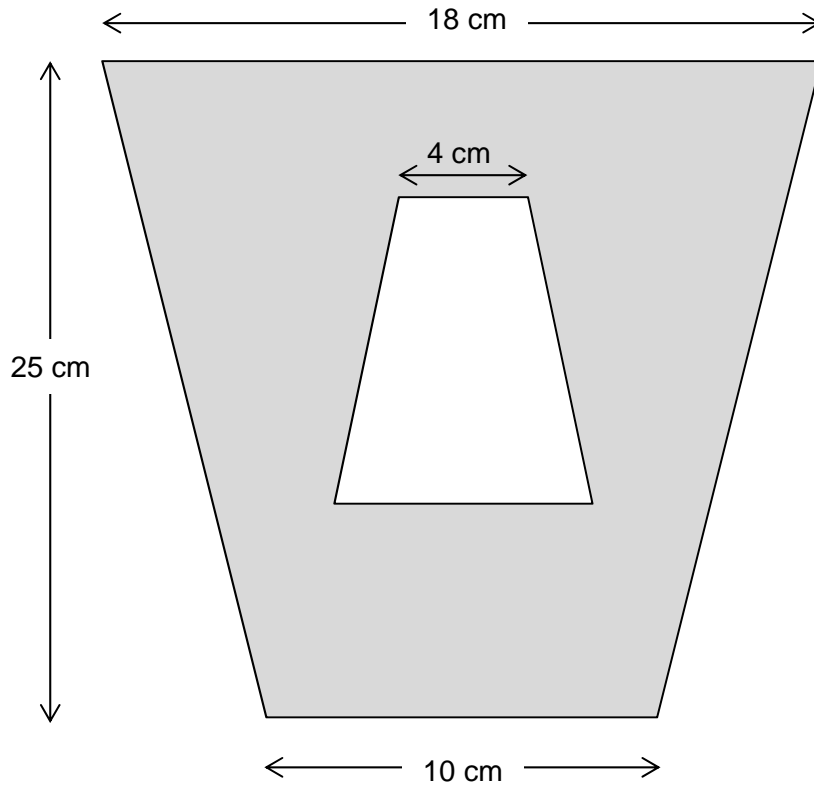

Show that the shaded area is 294 cm^2

[4 marks]

14 (b) The pattern has one line of symmetry.

Not drawn accurately

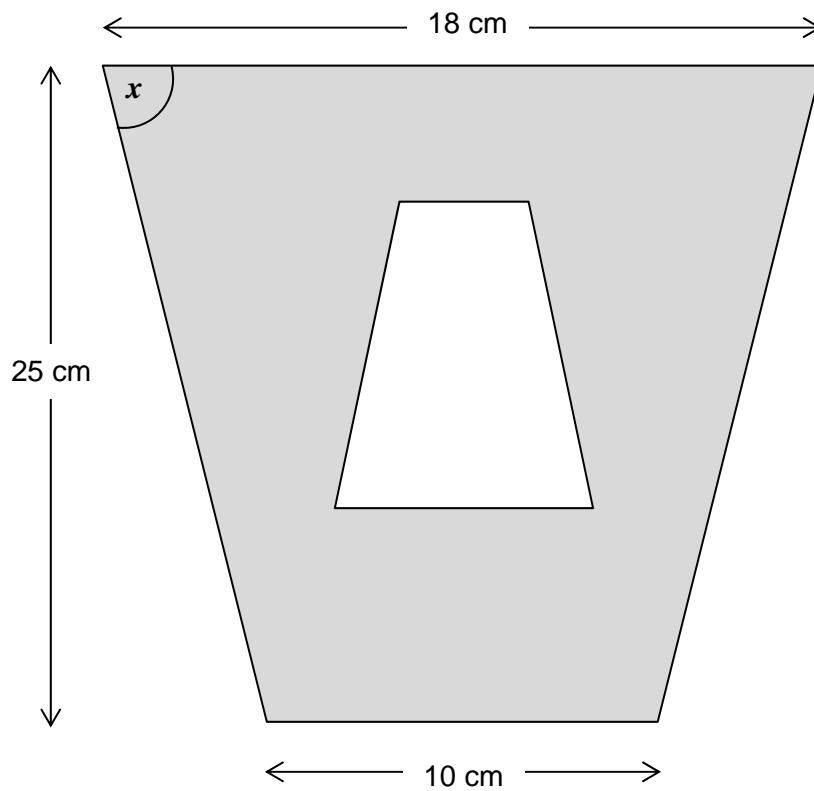

Work out the size of angle x .

[3 marks]

Answer _____ degrees

15 Ann picks a 4-digit number.

The first digit is **not** zero.

The 4-digit number is a multiple of 5

How many different 4-digit numbers could she pick?

[3 marks]

Answer _____

16 c is a positive integer.

Prove that $\frac{6c^3 + 30c}{3c^2 + 15}$ is an even number.

[3 marks]

17 The distance from the Earth to the Sun is 93 million miles.

Assume

it takes 365 days for the Earth to travel once around the Sun
the Earth travels in a circle with the Sun at the centre.

17 (a) Work out the average speed of the Earth in miles per hour.

[4 marks]

Answer _____ miles per hour

17 (b) It actually takes $365\frac{1}{4}$ days for the Earth to travel once around the Sun.

How does this affect your answer to part (a)?

[1 mark]

18 In the formula $T = (n - 6)^2 + 1$ n is a positive integer.

18 (a) Kim says,

“The value of T is always greater than 1
because $(n - 6)^2$ is always greater than 0”

Comment on her statement.

[1 mark]

18 (b) What is the only value of T that is a square number?

[1 mark]

Answer _____

19 $f(x) = 3x$

Circle the expression for $f^{-1}(x)$ **[1 mark]**

$-3x$

$\frac{3}{x}$

$\frac{1}{3x}$

$\frac{x}{3}$

20 y is directly proportional to \sqrt{x}

x	36	a
y	2	5

Work out the value of a .**[4 marks]**

Answer _____

- 21 A company makes boxes of cereal.
A box usually contains 450 grams of cereal.
Here are two options for a special offer.

Option A

20% more cereal
Price remains the same

Option B

Usual amount of cereal
15% off the price

Which option is the better value for the customer?
You **must** show your working.

[3 marks]

Answer _____

22

The histogram shows the ages, in years, of members of a chess club.

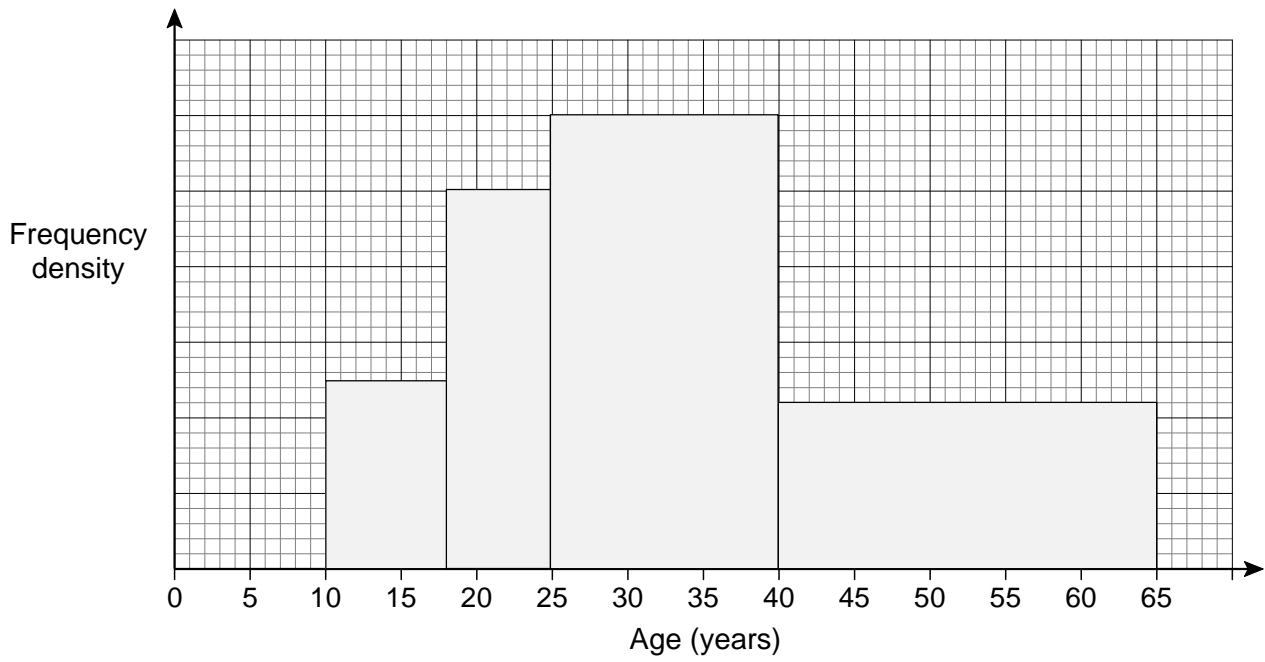

There are 22 members with ages in the range $40 \leq \text{age} < 65$

Work out the number of members with ages in the range $25 \leq \text{age} < 40$

[4 marks]

Answer _____

23

A bowl is a hemisphere with radius 6 cm

Water fills two-fifths of the volume of the bowl.

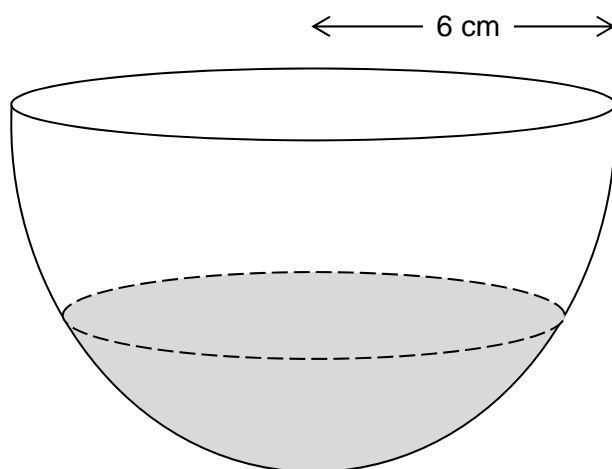

The water is poured into a hollow cone.

The depth of the water in the cone is 12 cm

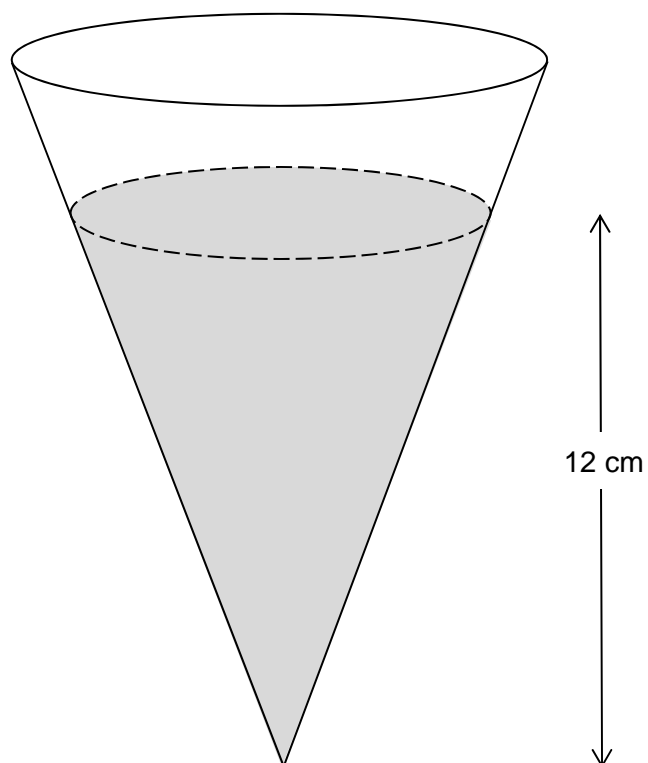

Volume of a sphere = $\frac{4}{3}\pi r^3$ where r is the radius.

Volume of a cone = $\frac{1}{3}\pi r^2 h$ where r is the radius and h is the perpendicular height

Work out the radius of the surface of the water in the cone.

[4 marks]

Answer _____ cm

- 24** A Big Wheel is modelled as a circle with centre O and radius 15 metres.
The wheel turns in an anticlockwise direction.
The lowest point on the wheel is always 2 metres above horizontal ground.

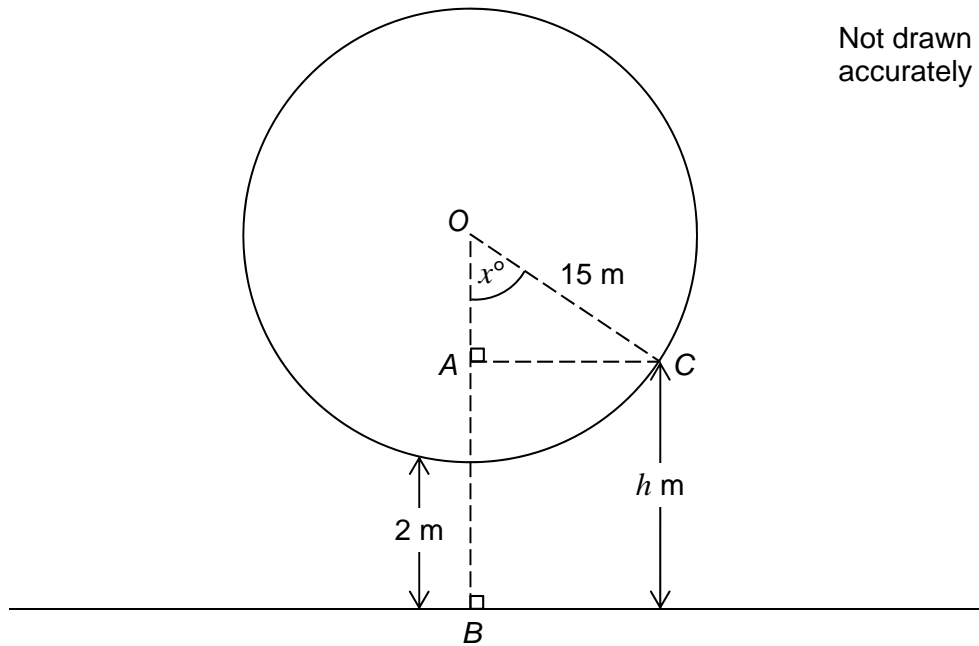

- 24 (a)** C is a point on the wheel, h metres above horizontal ground.
Angle $COB = x^\circ$

Show that $h = 17 - 15 \cos x^\circ$

[2 marks]

- 24 (b)** D is a point on the wheel.
Angle $DOB = 120^\circ$

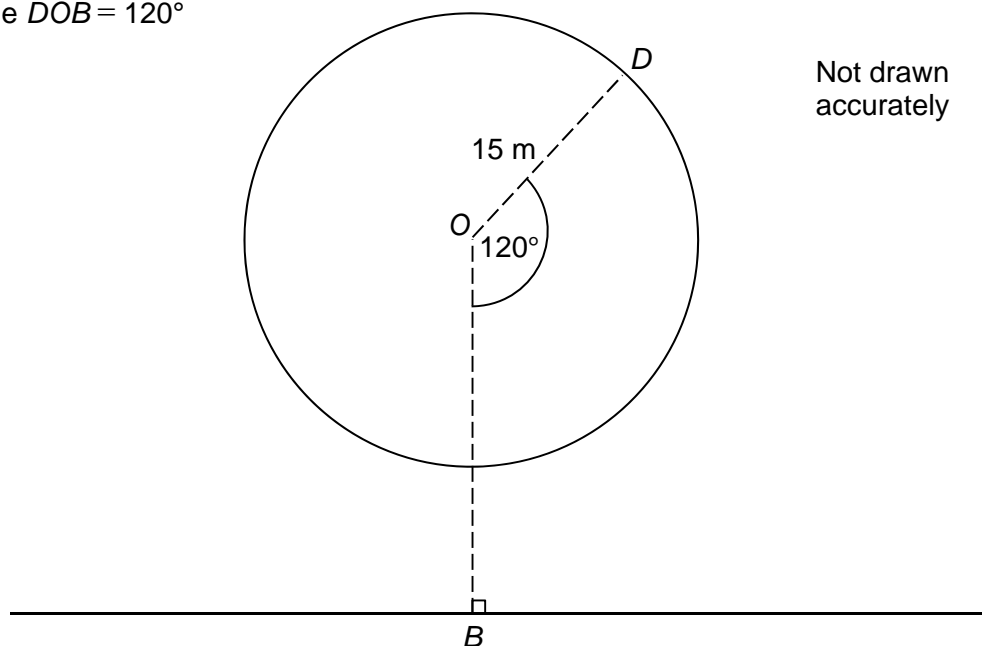

Work out the height of D above horizontal ground.

[2 marks]

Answer _____ metres

- 24 (c)** Here is a sketch of the graph $h = 17 - 15 \cos x^\circ$ for one **complete** turn of the wheel.
 P is the highest point on the graph.

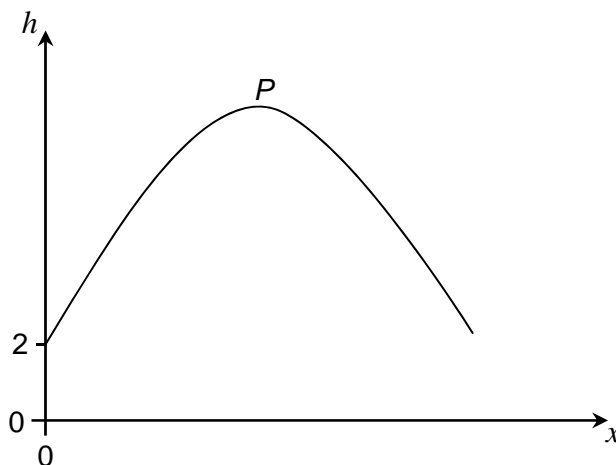

Work out the coordinates of P .

[2 marks]

Answer (_____ , _____)

25 $2x^2 - 6x + 5$ can be written in the form $a(x - b)^2 + c$
where a , b and c are positive numbers.

25 (a) Work out the values of a , b and c .

[3 marks]

$$a = \underline{\hspace{4cm}}$$

$$b = \underline{\hspace{4cm}}$$

$$c = \underline{\hspace{4cm}}$$

25 (b) Using your answer to part (a), or otherwise, solve $2x^2 - 6x + 5 = 8.5$

[3 marks]

Answer _____

Turn over for the next question

- 26** Two boxes are made with card.
The boxes are similar cuboids.
The smaller box has height 32 cm

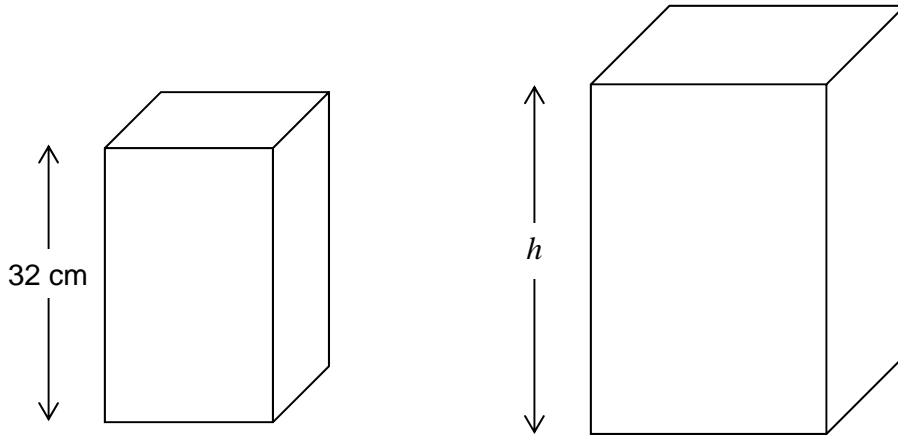

It takes 44% more card to make the larger box.

Work out the height, h , of the larger box.

[4 marks]

Answer _____ cm

END OF QUESTIONS